

Design  
Quality  
Technology

belenco<sup>®</sup>  
●●● quartz surfaces



# FACADE APPLICATION MANUAL



## ●●● TABLE OF CONTENTS

BELENCO QUARTZ SURFACES .....	04
BELENCO IS UNIQUE .....	05
FACADE APPLICATION TECHNIQUES .....	06
Mechanical Facade Assembly System and Its Advantages .....	06
Important Subjects to Consider in the Selection of Belenco Mechanical Facade Assembly System .....	07
MECHANICAL FACADE ASSEMBLY SYSTEM METHODS .....	09
Indirect Fixing .....	09
Direct Fixing .....	09
DOWEL ANCHOR METHOD .....	10
Pin Distances .....	10
Dead Load and Wind Load .....	11
Mechanical Facade Assembly Applications .....	12
Pin Anchor Application (Indirect Fixing) .....	12
Pin Anchor Application (Direct Fixing) .....	14
UNDERCUT METHOD .....	15
Stone Thickness .....	16
Preparation of Stone Cladding Materials .....	17
Mechanical Facade Assembly Applications .....	17
KERF METHOD .....	18
Preparation of Stone Cladding Materials .....	18
Mechanical Facade Assembly Applications .....	19
RESPONSIBILITY LIMITATION .....	19



●●● **BELENCO QUARTZ SURFACES**

Belenco manufactures in two production facilities located in Manisa Organized Industrial Zone in a total of 63,724 m<sup>2</sup>, 38,634 m<sup>2</sup> of which is closed area.

Since 2011, Belenco produces natural quartz surfaces with state-of-the-art technology of Breton S.p.A, Italy based leader company of natural and composite stone technology machinery with 3 casting and 4 polishing lines.



## BELENCO IS UNIQUE

Belenco demonstrated its R&D and Innovation vision since the first years of its establishment, naming the corporation: Peker Surface Designs Industry and Trace INC. showing that the design is the driving force for the company.

This vision, combined with strong investment policies, has given Belenco the privilege of being the “first” in various fields:

**2011** - After its establishment, Belenco quickly became the country’s most prominent exporter and fashion leader in its sector,

**2014** - Became the first producer and exporter of ready to be processed quartz surface category with its Belenco Plus investment.

**2015** - Increased the capacity by 100% with the help of second line investment, and

**2016** - Partnered with USA-based investment firm Darby Overseas.

**2017** - Produced Turkey’s first ever long vein quartz surfaces following Robotic Arm investment,

**2018** - Received the title of being the first R&D Center approved by the Ministry of Science, Industry and Technology in its sector.

**2019** - Partnership was established with Lotte Chemical Group (South Korea),

**2020** - During the year, the new factory area of 27 thousand 534 square meters was completed and the 3rd line production started. With the addition of the second facility, Belenco has reached a production capacity of 2 million square meters in a total facility area of 63,724 m<sup>2</sup>; taking its place among the world’s leading quartz surface producers.





## FACADE APPLICATION TECHNIQUES

### Mechanical Façade Assembly System and Its Advantages

Facade mechanical assembly system (curtain wall system) is a method of fixing the cladding material to be applied to the facade to the building surface with various metal anchoring elements. In this method, each cladding material to be applied to the facade is fixed to the building independently of each other. Thus, each cladding material can be easily repaired, replaced or cleaned in the desired condition. The fact that the cladding materials are not in direct contact with each other will ensure that they move independently of each other during the expansion and shrinkage that may occur due to temperature changes. For this reason, Belenco Quartz Surfaces are recommended to be applied to the facade with this method.

#### Safety

The cladding materials applied along the facade of the building are exposed to many factors such as gravity, wind load, expansion and shrinkage movements that occur due to temperature changes, and vibration. The possibility of the cladding material losing its bond with the wall and falling because of these factors poses a great threat to pedestrian traffic safety. These are the most important factors to consider in facade applications.

#### Natural Ventilation and Vapor Permeability

Natural ventilation and vapor permeability are very important for the building to breath and for preventing condensation inside. These systems, also called ventilated facades, help protect the building from overheating in summer and cooling in winter. Facades covered with Belenco slabs provide the necessary comfort by meeting these conditions.

#### Sound Insulation

Sound insulation is a very important parameter for life especially in big cities. The air gap between the cladding material and the thermal insulation contributes to the sound insulation and provides significant benefits in preventing noise.

#### Belenco Technical Specifications

The weight, sizes and thickness of the cladding material to be used on the facade are the factors that should be considered in the selection of mechanical curtain walling. Belenco slabs can be sized precisely to the sizes required by projects for facade applications. (Table-1)

Table-1.  
Belenco Technical Specifications

Standards	Specifications	Units	Values
EN-14617-1	Water Absorption	%	W4 ≤ 0,05
EN-14617-1	Apparent Density	(g/cm <sup>3</sup> )	2,0-2,5
EN-14617-2	Flexural Strength	(MPa)	F4 ≥ 40
EN-14617-9	Impact Resistance	(Joule)	≥3
EN-14617-4	Abrasion Resistance	(mm)	A4 ≤29
EN-14617-5	Freeze and Thaw Resistance	(%)	KM <sub>f25</sub> : 98
EN-14617-10	Chemical Resistance		C4
EN-14617-11	Linear Thermal Expansion Coefficient	(10 <sup>-6</sup> / °C)	20-35
EN 12664	Thermal Conductivity Coefficient	(W/mK)	0,777
EN-14617-6	Thermal Shock Resistance	(%)	Δm=0,48 ΔR <sub>f,20</sub> =5
EN 13501-1	Reaction to Fire Class		A2 s1 d0
EN-14617-12	Dimensional Stability		Class A
EN-14617-13	Electrical Resistance	(Ω)	*Rs: 3x10 <sup>12</sup> *Rv: 2x10 <sup>12</sup>
EN-14231	Slip Resistance	(SRV)	Wet 4,5 Dry 41
EN-14617-8	Resistance to Fixing (Pin)	(N)	≥2500
	Resistance to Fixing (Dowel)	(N)	Avg. 9000

Table-2.

Average weight of Belenco Quartz Surfaces sized in different sizes and thicknesses

Sizes	Weight (kg)	
	2 cm	3 cm
30 x 30 cm	4	6
50 x 50 cm	11	16
75 x 75 cm	25	37
50 x 100 cm	22	33
75 x 100 cm	33	50
100 x 150 cm	66	100

Compliance of the sizes mentioned above with the relevant project must be checked with the calculations made within the framework of regulations and standards. If different sizes are desired to be used, compliance can be checked for the relevant dimensions with calculations or our technical team can be consulted.

## Important Subjects to Consider in the Selection of Belenco Mechanical Façade Assembly System

The selection of facade mechanical assembly system varies depending on many factors. These factors can be listed as wall type, features of the cladding material (thickness, weight, linear thermal expansion), building height (wind load), seismic load, snow load, general design of the building. The selection of the appropriate configuration must be determined by the project manager according to the current regulations and standards of the relevant country for each project.

## Building Height

The static and mechanical properties of the building and the impact of natural weather conditions on the building vary depending on the height of the building. For this reason, in the projecting of buildings, all details must be prepared specifically for the building. In addition, the conformity of the system must be checked by making tests and calculations in international standards, taking into account the height of the building. Wind loads are an important factor to be taken into consideration in the design of the buildings. Wind pressure values are given in the table below as a guide according to the building height.

Table-3. Wind Pressure Values Depending on Building Height according to TS 498

Building Height (m)	Wind Speed v (m/s)	Wind Load q (kN/m <sup>2</sup> )	Wind Pressure (kN/m <sup>2</sup> )	Suction/Speed Pressure (Middle of the Building) (kN/m <sup>2</sup> )		Suction/ Speed Pressure (Edge of the Building) (kN/m <sup>2</sup> )
			C <sub>p</sub> :0,8	C <sub>p</sub> :0,5 h/b:0,25	C <sub>p</sub> :0,7 h/b:0,5	C <sub>p</sub> :2,0 b/8 ≤2m
0-8	28	0,5	0,5	0,25	0,35	1,0
8 – 20	36	0,8	0,8	0,40	0,56	1,6
20 – 100	42	1,1	1,1	0,55	0,77	2,2

\* Wind Pressure:  $1,25 \times C_p \times q$       Suction:  $C_p \times q$

h: Building Height    b: Building Width    C<sub>p</sub>: Correction Factor

\*When calculating the wind pressure, if no other factor is determined in the project, it is multiplied by 1.25 safety factor.

## Seismic Load

An object that is stationary or moving with a constant speed resists a force coming from outside and changing its speed, in the opposite direction to the force affecting due to its weight. This is called an inertia force. The movement of the ground during an earthquake and the resistance of the structure to this force with its weight is an example of inertia force.

The generated force must be calculated by the project manager specifically for each project as well as depending on the factors such as mass of the cladding element, building importance coefficient, load-bearing system behavior coefficient. Information that will be used in the calculation can be found on “Earthquake Building Regulations of Turkey”.

## Wall Type

The wall type of the building where the cladding will be made is another criterion to be considered when choosing mechanical curtain walling. Indirect fixing systems are preferred in cases where the wall is not a load-bearing, a certain distance is required between the wall and the cladding material, the building plumb is slipped and the cladding stones are large. If the wall is a load-bearing, both direct and indirect fixing



systems can be applied. Apart from these, the wall construction type and quality must be taken into account in determining the dowels required for fixing the anchors. Because different types of dowels are used depending on whether the wall is concrete, brick, filled or perforated block and steel construction.

### Joint Gaps

The cladding material to be used will expand and shrink with thermal movement due to its nature. As a result of these thermal movements, joint gaps must be left while cladding is applied so that the changes in the size of the stone can be made freely. Joints also provide ease of assembly.

The joint distance to be left is directly proportional to the thermal expansion coefficient, size and environmental temperature changes of the stone cladding material.

Although the joint gap to be selected varies according to the project, it is recommended that it is not less than 5mm. Expansion joints may also be used if required according to the project.

## FAÇADE MECHANICAL ASSEMBLY SYSTEM METHODS

Facade mechanical assembly techniques are basically divided into direct and indirect according to the type of fixing to the facade. There are more than one method according to the way the stone cladding material is fixed to the system. Multiple systems can be used together according to the requirements of the project.

### Indirect Fixing:

In the indirect fixing method, the stone cladding material is fixed on the frame made of brackets and profiles on the facade surface. In this method, which can also be preferred on non-bearing facades, the profiles are fixed to the brackets placed on the load-bearing columns between the floors. Then, the anchor bodies selected in accordance with the project are fixed to the profiles and the stone cladding material is mounted on the facade with the desired fasteners. It has fewer drilling points than direct applications. Due to its high bearing capacity, it allows the use of larger stones.

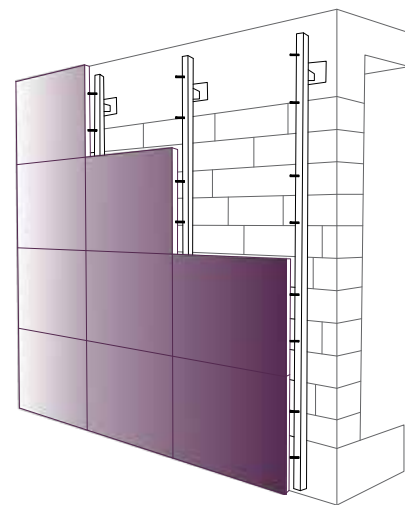

Figure-1: Indirect fixing

## Direct Fixing:

In the direct fixing method, the stone cladding material is fixed directly to the bearing facade with the anchor bodies required by the project. The insulation material is drilled or cut at each anchoring point. Anchoring elements are fixed to the bearing facade with steel dowels. Then, the desired bonding method is selected and the stone cladding materials are mounted on the facade by means of anchors.

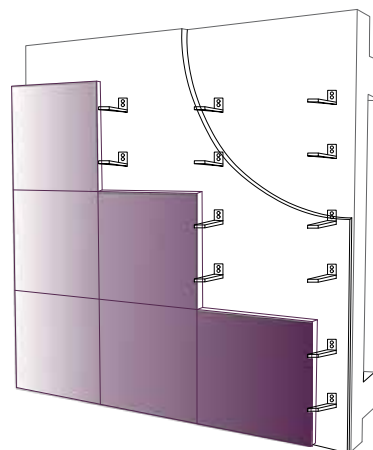

Figure-2: Direct fixing

Belenco cladding material is recommended to be fixed to the system with pin anchors.

## DOWEL ANCHOR METHOD

It is a mechanical façade assembly method applied by drilling 2 sides of the stone cladding material at 4 points in total and fixing it to the facade with the help of pin anchors. Stones can be applied horizontally or vertically, depending on the condition required by the project. Thanks to the pin system anchor bodies, it can be applied both directly and indirectly. It must be taken into account that the elements to be selected in the pin system are stainless steel.

### Pin Distances

How far the holes will be from the corner of the stone can be calculated with the formula below.

$$\alpha = \frac{L_1}{4} \times \frac{\sqrt{2}}{1 + \sqrt{2}/2} \approx 0.21 \times L_1$$

$\alpha$ : The distance between the pin hole and the corner of the stone  
 $L_1$ : The length of the edge where the pin holes will be drilled

In practice, however, the optimum distance of the pin holes to the corner of the stone can be used as  $L_1 / 4$

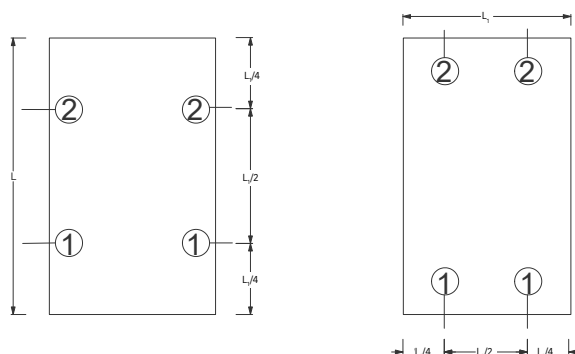

Figure-3: Distance of the holes to be drilled for the pin

## Dead Load and Wind Load

In the pin system, the loads on the anchor elements vary according to the horizontal or vertical application method. The dead loads of the stones, both horizontally and vertically, are covered by the two anchors below. Wind loads, on the other hand, affect all anchors. The dead load of the stone varies according to the stone thickness, stone size and density of the stone. If no other factor is specified in the project, the dead load is multiplied by 1.35 which is the safety factor.

$$\text{Dead load} = \text{Stone height} \times \text{Stone width} \times \text{Stone thickness} \times \text{Stone density}$$

In the horizontal application method, the 2 anchor elements that are at the bottom share the dead load of the upper stone. Thus, each anchor below encounters half the weight of the stone dead load.

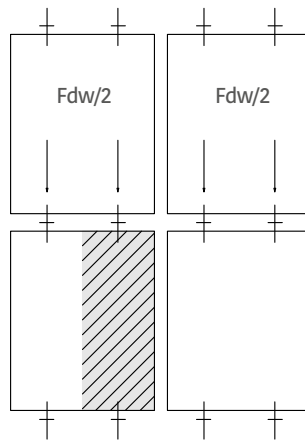

**Figure-4: Horizontal Application**

Fdw/2: Dead load/2

In vertical application, the bottom anchors bear half the dead load of the stone on both the right and the left, so they bear the dead load of a full stone in total.

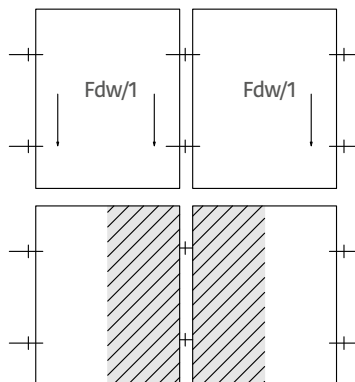

**Figure-5: Vertical Application**

Fdw/1: Dead load

Wind loads are dependent on the height of the building, environmental factors, facade width etc. regardless of the stone. Wind loads vary according to each project. The values calculated as an example are shown in Table-3.

## Mechanical Facade Assembly System Application

### Pin Anchor Application (Indirect Fixing)

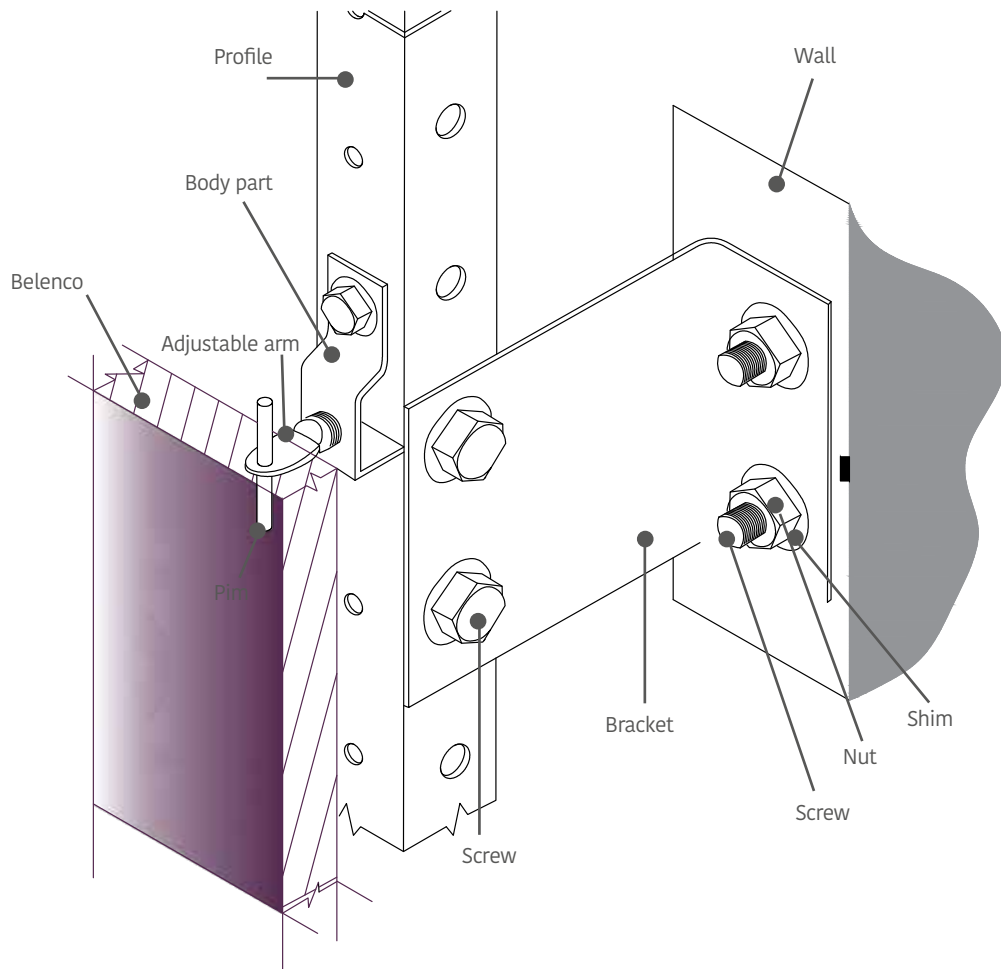

Figure-6: Indirect Fixing

- Before starting the application, the implementer makes the necessary checks. (Surface slope, control of drawings, surface dryness, etc.)
- Horizontal and vertical axes suitable for the project are determined on the assembly surface.
- The distance between the stone cladding material and the wall are adjusted according to the measurements in the project.
- Brackets are fixed with steel dowels to the beams between floors. The distance between the brackets on the horizontal axis is determined by the project-specific static calculations.

- While the brackets are fixed, the insulation materials are cut in accordance with the brackets and the remaining holes are closed after the fixing process is completed.
- Profiles are mounted on brackets using the appropriate bolt-shim-nut set.
- Anchor bodies suitable for the project and selected by the project manager are bonded to the profiles with a suitable bolt-shim-nut set.
- The adjustable arms selected in accordance with the distance between the wall and the cladding material are fixed to the anchor bodies. After the distance is adjusted, the nuts are tightened and fixed.
- Stainless steel pins are inserted into the holes in the adjustable arms.
- Belenco products to be used in cladding are carefully drilled at the points specified in the project. These holes should be 2-3 mm more than the diameter of the pin to be used.
- It is recommended to drill the holes  $L1 / 4$  away from the corner of the stone.
- First, after the polyester-based adhesive is applied to the holes on the underside of the stones, the stones are placed on the relevant pins. These pins will bear the dead load of the stone and the wind load.
- Plastic tubes are then inserted into the holes on the top of the stones. The purpose of plastic tubes is to absorb wind load and prevent vibration.
- Pins that will remain at the top are inserted into the holes in which plastic tubes are placed. The anchor body with the inserted pins is fixed to the profiles by means of nuts.
- Joint gaps can be left free or filled according to the project type. If it is desired to fill the joint gaps, ventilation is provided by leaving. Openings at the top and bottom vertical joints to prevent corrosion. Neutral silicone or polyurethane based products can be used as filling material.

## Pin Anchor Application (Direct Fixing)

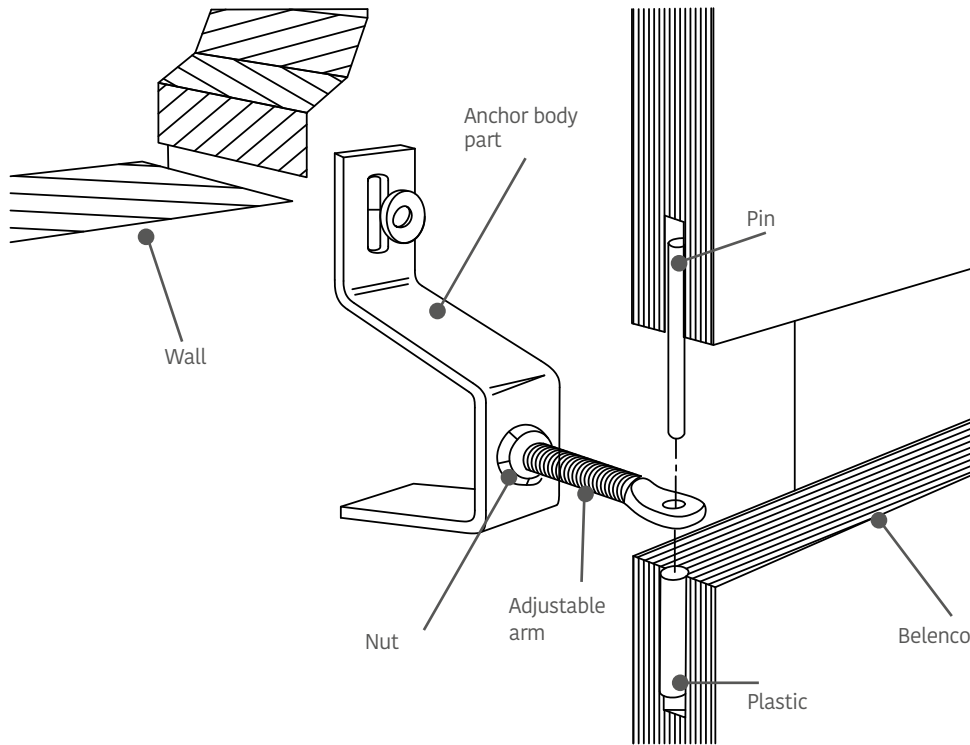

Figure-7: Direct Fixing

- Before starting the application, the implementer makes the necessary checks. (Surface slope, control of drawings, surface dryness, etc.)
- Horizontal and vertical axes suitable for the project are determined on the assembly surface.
- The distance between the stone cladding material and the wall is adjusted according to the measurements in the project.
- Anchor bodies suitable for the project and selected by the project manager are mounted on the bearing facade with steel dowels.
- Insulation materials are cut according to the anchor bodies and properly closed after the fixing is completed.
- The adjustable arms selected in accordance with the distance between the wall and the cladding material are fixed to the anchor bodies. After the distance is adjusted, the nuts are tightened and fixed.
- Stainless steel pins are inserted into the bearings in the adjustable arms.

- Belenco products to be used in cladding are carefully drilled at the points specified in the project. These holes should be 2-3 mm more than the diameter of the pin to be used.
- It is recommended to drill the holes  $L1 / 4$  away from the corner of the stone.
- First, after the polyester-based adhesive is applied to the holes on the underside of the stones, the stones are placed on the relevant pins. These pins will bear the dead load of the stone and the wind load.
- Plastic tubes are then inserted into the holes on the top of the stones. The purpose of plastic tubes is to absorb wind load and prevent vibration.
- Pins that will remain at the top are inserted into the holes in which plastic tubes are placed.
- Joint gaps can be left free or filled according to the project type. If it is desired to fill the joint gaps, ventilation is provided by leaving openings at the top and bottom vertical joints to prevent corrosion. Neutral silicone or polyurethane based products can be used as filling material.

## ●●● UNDERCUT METHOD

In this method, the cladding material is mounted to the system by means of dowels placed in the holes on the back surface. A minimum of 4 dowels are placed on the back surface of each stone. The number of dowels may vary depending on the project requirements. Special tipped drilling machines must be used to drill the holes where the dowels will be placed.

Since the anchors to be used in this system will remain behind the stone, this method is known as the invisible fixing method.

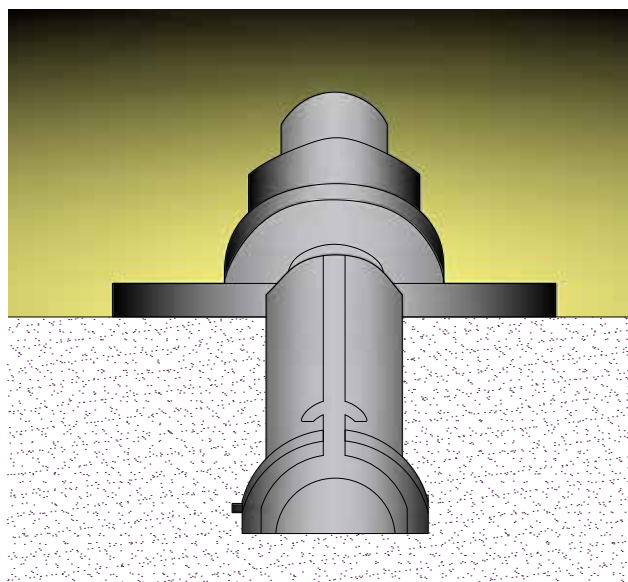

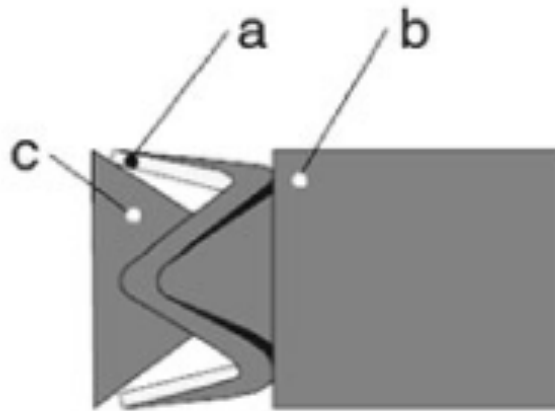

Figure: Typical dowel; (a) expansion ring, (b) sleeve (c) conical bolt

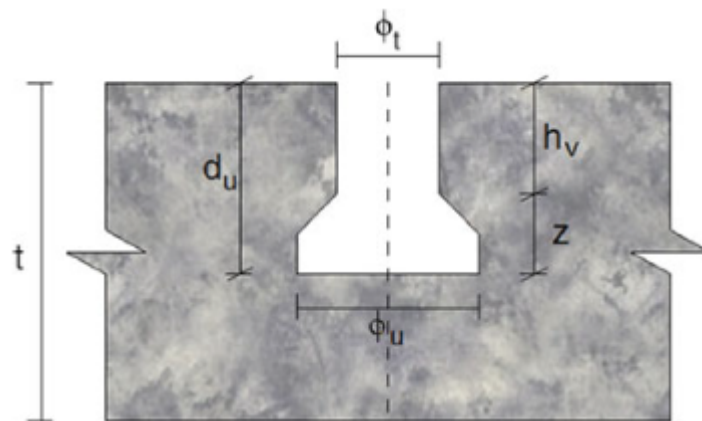

Figure: Dowel hole drilled in the back of the cladding material; (t) cladding material thickness, (du) dowel depth, (hv) fixed diameter depth, (z) variable diameter depth, ( $\phi_t$ ) cylindrical dowel hole diameter, ( $\phi_u$ ) undercut diameter

### Stone Thickness

The selection of stone thickness varies according to the wind load, stone size, mechanical properties of the stone as well as the anchor elements to be used.

In the doweled method, the following formula must be taken into account in addition to other stone thickness calculations. In a typical dowel, the depth (z) of the variable diameter is 4 mm and the fixed diameter depth (hv) is 11 mm. When these values are put in place, the minimum cladding material thickness is 25 mm. According to this information, this method is recommended to be preferred on 30 mm thick Belenco quartz surfaces.

$$t_{\min} \geq \frac{5}{3} \times (z + h_v)$$



## Preparation of Stone Cladding Materials

It is necessary to drill dowel holes on the back surface of Belenco quartz surfaces, which are sized as desired, with special drilling machines. At this stage, the stones are placed on a suitable ground with their back facing up. Marking is made by determining the points where the holes will be drilled. The stones, which are ready for drilling, are drilled with precision by the technical operator with the help of a special machine.

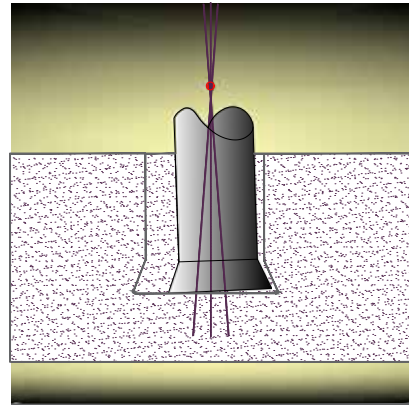

Drilling dowel hole

Suitable dowels are placed in the holes. Although the dowels are generally preferred as metric 6 or 8, they may vary according to the project and the manufacturer. It is struck with the help of a suitable apparatus on the sleeves of the dowels placed. In this way, the expansion ring expands in the hole and clings to the stone.

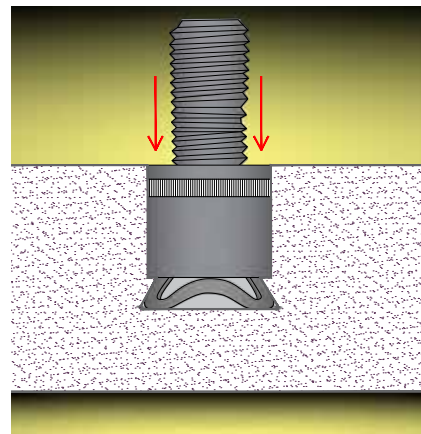
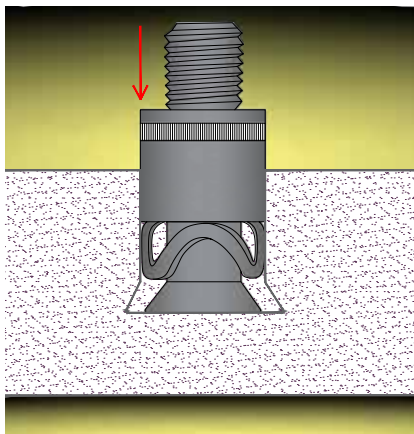

Fixing dowels

## Mechanical Facade Assembly Applications

### Undercut Method Application

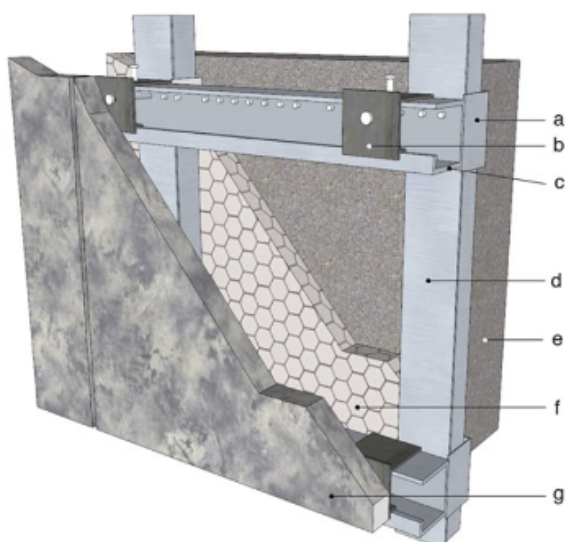

Undercut anchor application;

- (a) wall bracket,
- (b) cladding material bracket,
- (c) horizontal profile,
- (d) vertical profile,
- (e) wall,
- (f) insulation material
- (g) stone cladding material

- Before starting the application, the implementer makes the necessary checks. (Surface slope, control of drawings, surface dryness, etc.)
- Horizontal and vertical axes suitable for the project are determined on the assembly surface.
- The distance between the stone cladding material and the wall is adjusted according to the measurements in the project.
- Brackets are fixed with steel dowels to the beams between floors. The distance between the brackets on the horizontal axis is determined by the project-specific static calculations.
- While the brackets are fixed, the insulation materials are cut in accordance with the brackets and the remaining openings are closed after the fixing process is completed.
- Vertical and horizontal profiles are mounted on brackets using a suitable bolt-shim-nut set.
- The preparation stages of the stone cladding materials must be completed. The dowels of the completed cladding materials are fitted with brackets that will allow them to be hung on horizontal profiles.
- All the completed stone cladding materials are fixed by hanging on the horizontal profiles.
- Joint gaps can be left free or filled according to the project type. If it is desired to fill the joint gaps, ventilation is provided by leaving. Openings at the top and bottom vertical joints to prevent corrosion. Neutral silicone or polyurethane based products can be used as filling material.

## ●●● KERF METHOD

Kerf system is a method of assembling the cladding materials with kerfs on the lower and upper edges of the facade by fixing them to clips / profile anchors.

### Preparation of Stone Cladding Material

Before the assembly of the stone cladding material, a kerf is opened on the upper and lower edges of the stone with the help of special equipment. During the grooving process, the kerfs must be opened in the middle of the stone edge in order to protect the strength of the stone.

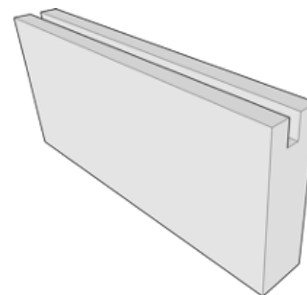

Cladding stone with a kerf

## Mechanical Facade Assembly Applications

These systems, like other systems, are indirectly fixed to the facade by means of brackets and vertical profiles. Vertical and horizontal profile distances vary according to the project.

Anchors made of stainless steel or aluminum are divided into two as continuous or split. In line with the static calculations made in the project (according to the flexural strength of the cladding material, size, wind load, seismic load, etc.), the type and size of the anchor to be used, the length of the kerfs to be opened on the edges of the cladding material is determined.

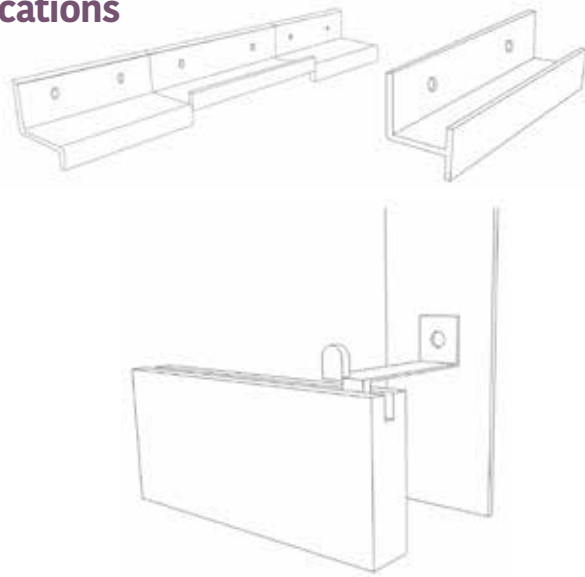

Split (left), continuous (right) and clip-on (bottom) anchors

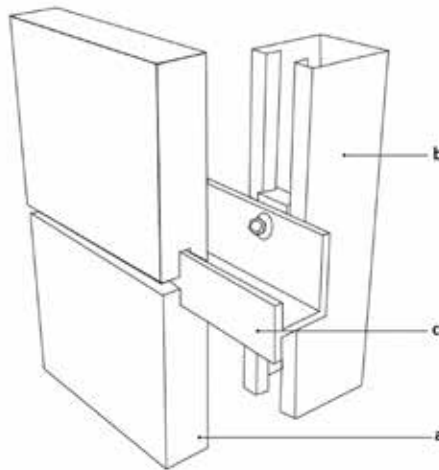

Stone with a kerf (a), vertical profile (b), horizontal profile (c)

## RESPONSIBILITY LIMITATION

This document is prepared to describe how Belenco products can be used in facade applications and is based on our best knowledge and experience. However, the information written here may vary for each project and must be evaluated by authorized project managers and approved after trials and calculations when necessary. Our company cannot be held responsible for these variations. In practice, up-to-date and legal regulations must always be taken as basis

**Headquarters and Factory:**

**Factory I :**  
Manisa Organize Sanayi Bölgesi 4.Kısım  
Keçiliköy OSB Mahallesi  
Ahmet Nazif Zorlu Bulvarı No: 22  
Yunusemre - MANİSA / TÜRKİYE

**Factory II :**  
Manisa Organize Sanayi Bölgesi 4. Kısım  
418. Cadde  
Yunusemre - MANİSA / TÜRKİYE

T: +90 236 213 03 43 F: +90 236 213 03 03  
E: info@belenco.com

**Istanbul Office:**  
Akmerkez Residence Kültür Mah. Adnan  
Saygun Cad. Ulus-Yolu No: 3 K: 12 D: 12 A1 P. K.  
34340 Etiler - Beşiktaş - İSTANBUL / TÜRKİYE  
T: +90 212 871 20 95 F: +90 212 871 20 96  
E: info@belenco.com

